

NOTE

DO NOT ATTACH INTO SOLID SUBSTRATE BELOW.
BOOT SHALL NOT INTERSECT STANDING SEAM VERTICAL LEG. INSTALL IN FLAT AREA OF PANEL ONLY.
IF USING A SQUARE BOOT DETAIL BE SURE TO SET BOOT IN A DIAGONAL OR DIAMOND TO ALLOW WATER FLOW.

FASTENER NOTE

ALL EXTERIOR FASTENERS ARE TO BE EITHER STAINLESS OR PLATED CARBON STEEL.

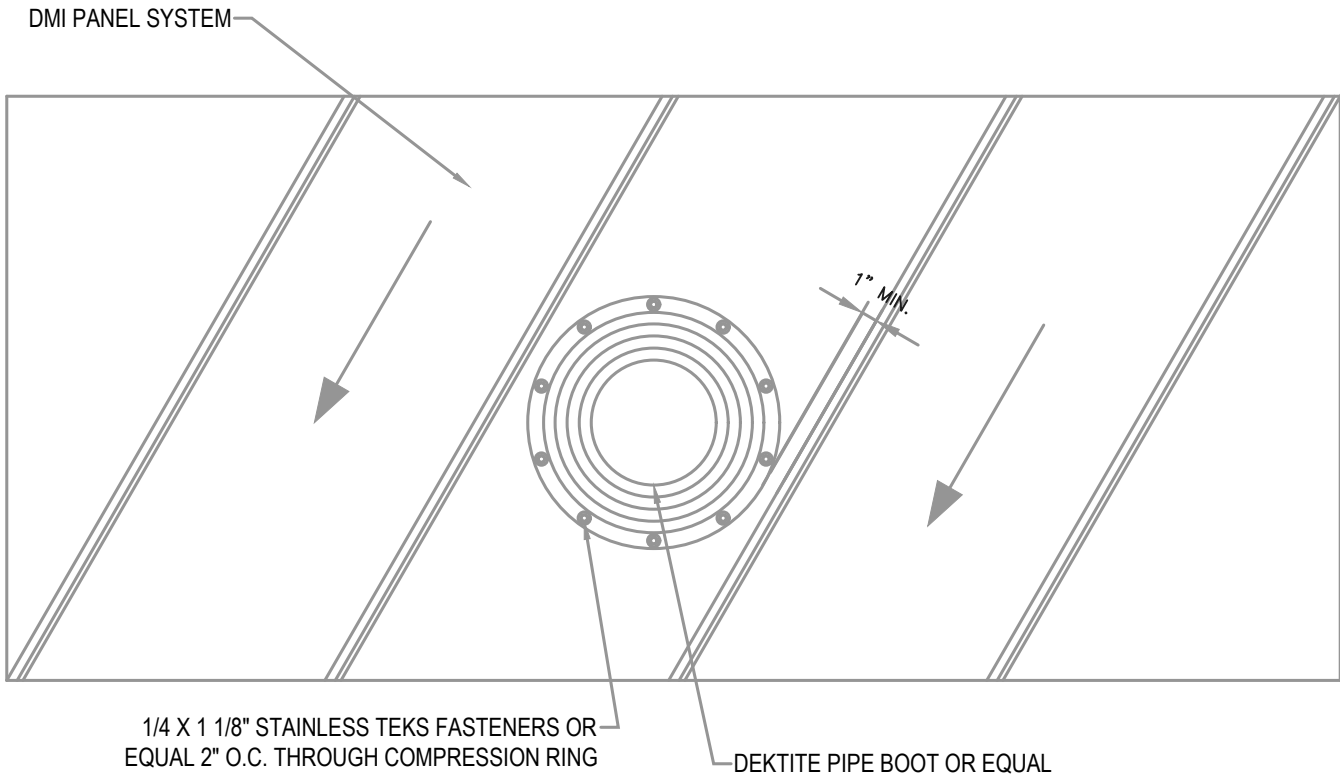
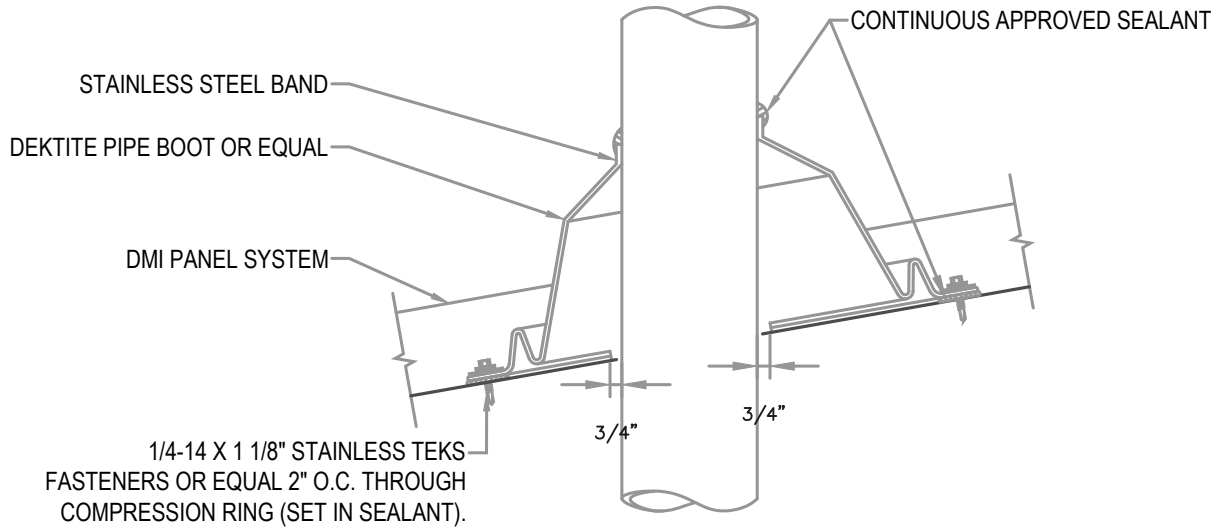

HYDROSTATIC PIPE BOOT DETAIL

• PROVEN • DEPENDABLE • SUSTAINABLE •
METAL ENVELOPE SYSTEMS SINCE 1988

WWW.DMIMETALS.COM

Detail:

TL25 09-00-WH

Issue/Rev Date:

01/17

Scale:

3"=1'-0"