

**FLASHING LAP NOTE**

LAP EXPANSION JOINT AND J CLOSURE 2" MINIMUM WITH 2 ROWS OF BUTYL SEALANT.

**FASTENER NOTE**

ALL EXTERIOR FASTENERS ARE TO BE EITHER STAINLESS OR PLATED CARBON STEEL.

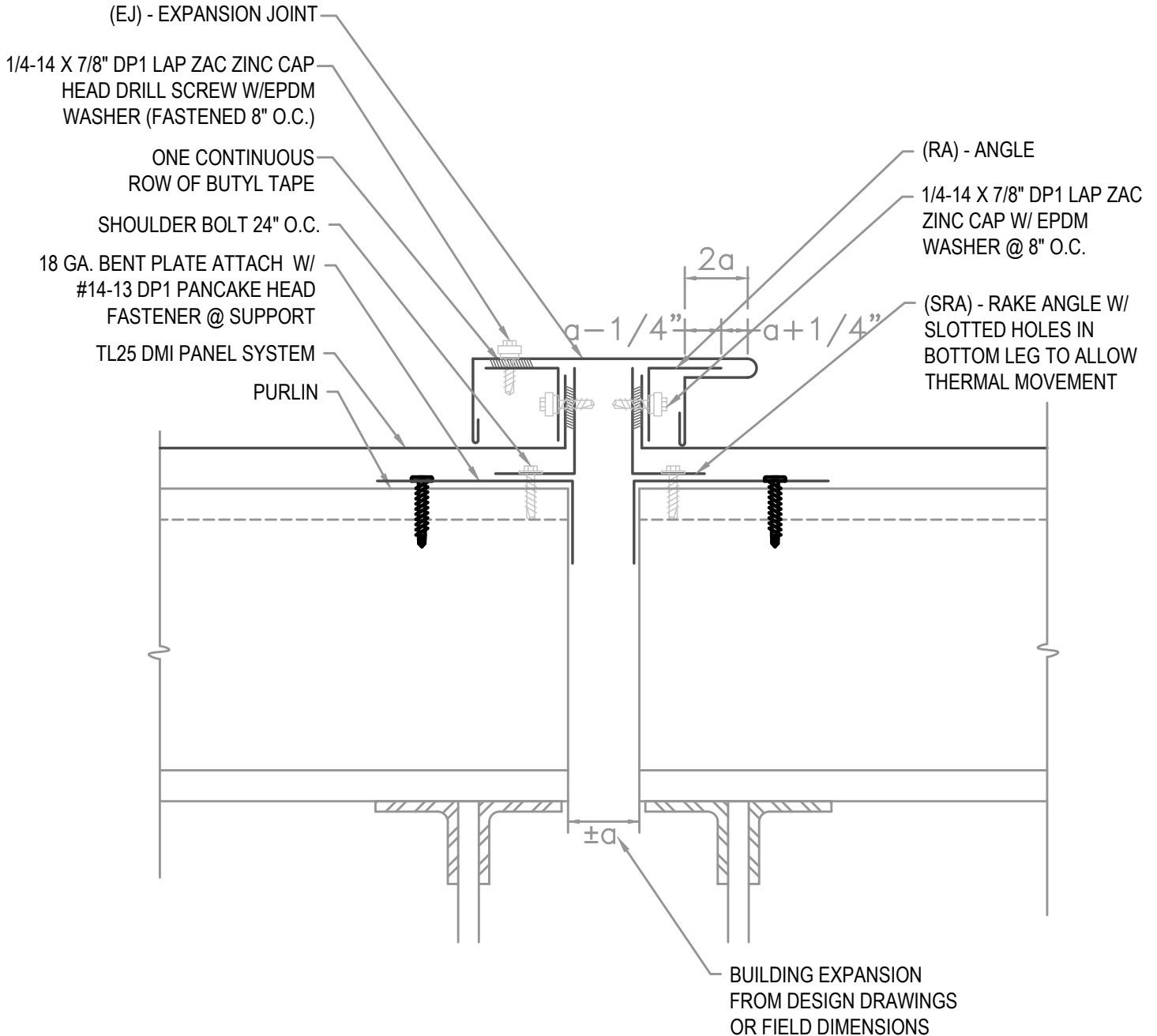

**HYDROSTATIC EXPANSION JOINT**

**• PROVEN • DEPENDABLE • SUSTAINABLE •**  
**METAL ENVELOPE SYSTEMS SINCE 1988**

WWW.DMIMETALS.COM

Detail:  
**TL25 08-00-PH**

Issue/Rev Date: **09/18** Scale: **3"=1'-0"**