

FLASHING LAP NOTE

LAP RAKE EDGE AND FASCIA 2" MINIMUM WITH 2 ROWS OF BUTYL SEALANT.

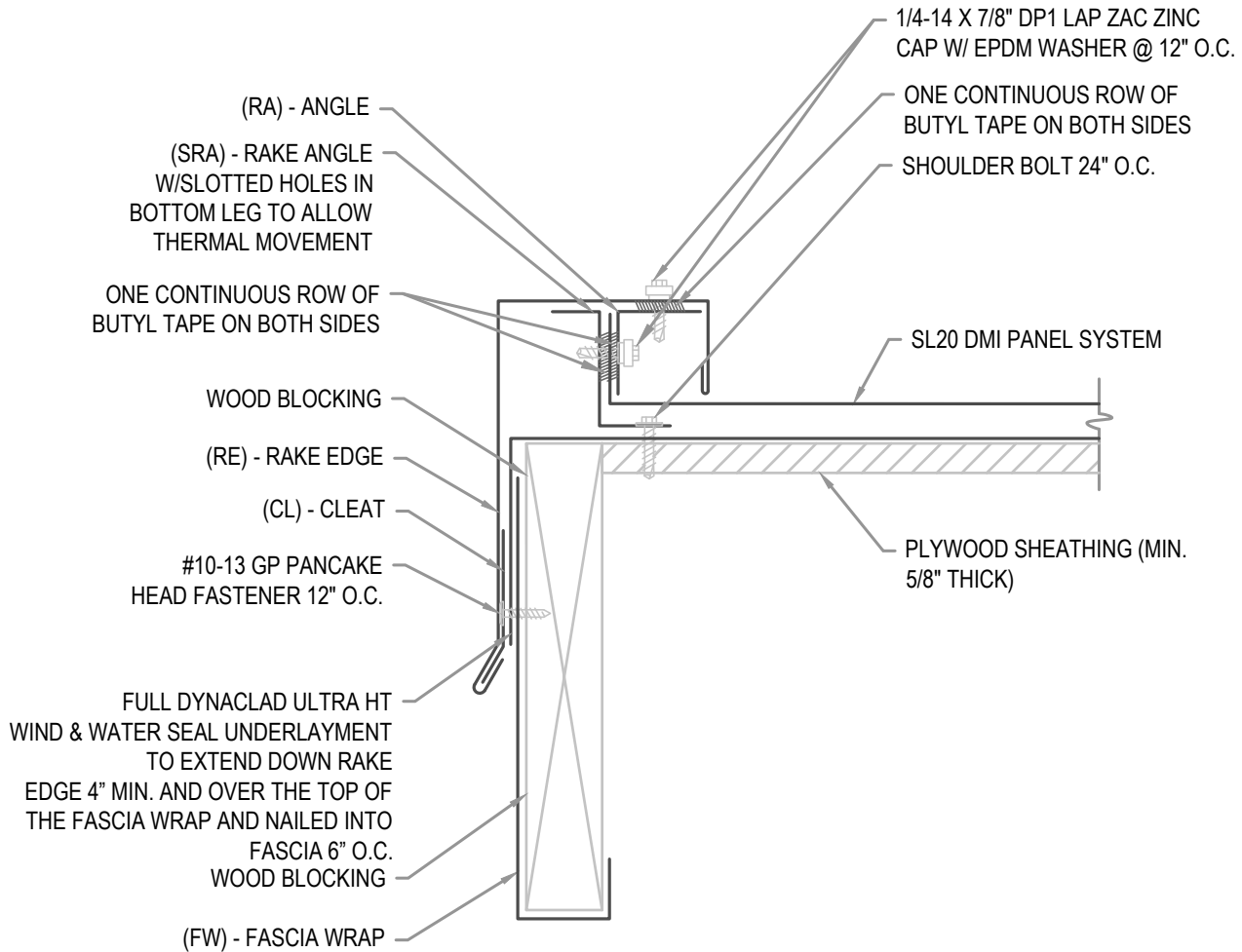

HYDROSTATIC RAKE EDGE

• **PROVEN** • **DEPENDABLE** • **SUSTAINABLE** •
METAL ENVELOPE SYSTEMS SINCE 1988

WWW.DMIMETALS.COM

Detail:

SL20 04-01-WH

Issue/Rev Date:

01/17

Scale:

3"=1'-0"