

SEE DMI DYNACLAD EDGE INSTALLATION GUIDE FOR COMPLETE FASTENING AND INSTALLATION INFORMATION FOR ES-1 RATED SNAP-ON COPING

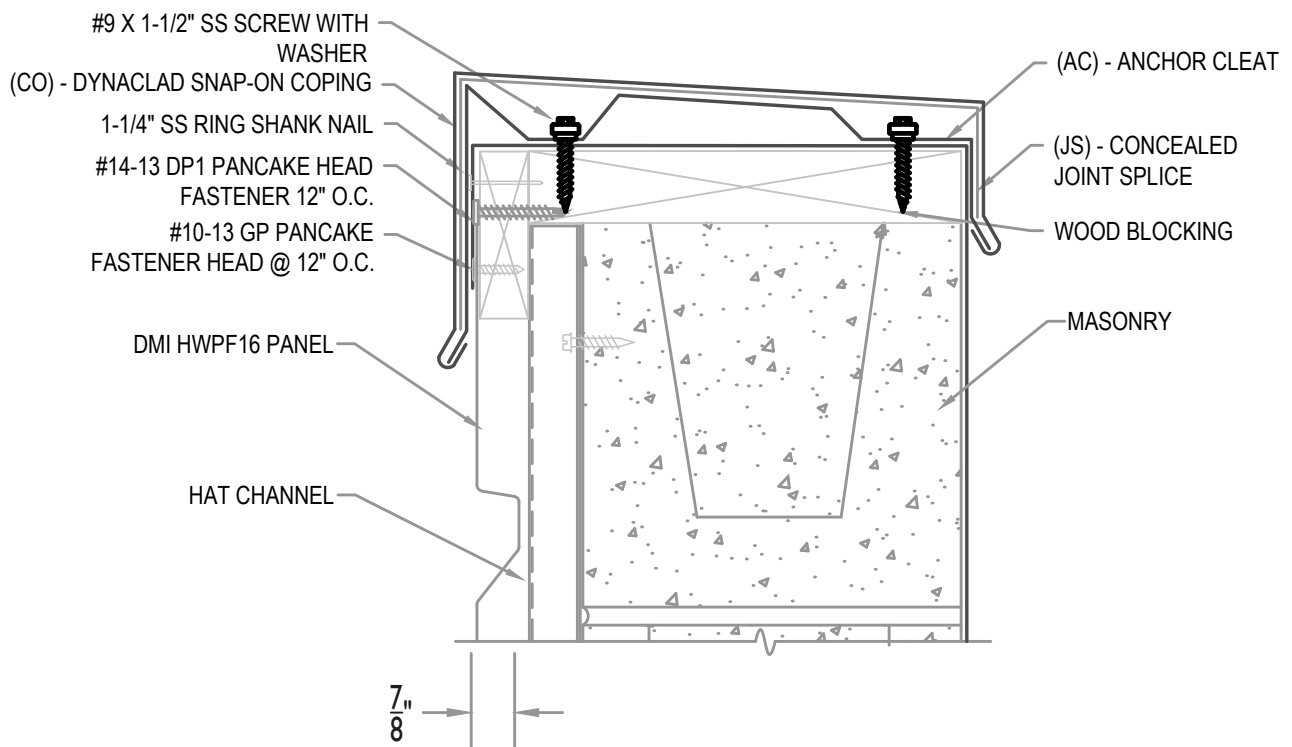

MAXIMUM PANEL ATTACHMENT FASTENER SPACING IS 24" O.C. ALL FASTENERS TO PENETRATE WOOD 3/4" MIN. AND METAL FRAMING 1/2" MIN.



COPING WITH HAT CHANNEL

• PROVEN • DEPENDABLE • SUSTAINABLE •

METAL ENVELOPE SYSTEMS SINCE 1988

WWW.DMIMETALS.COM

Detail:

HWPF16-H-04-01

Issue/Rev Date:

04/19

Scale:

3"=1'-0"