

MAXIMUM PANEL ATTACHMENT FASTENER SPACING IS 24" O.C. ALL FASTENERS TO PENETRATE WOOD 3/4" MIN. AND METAL FRAMING 1/2" MIN.

SEE DMI DYNACLAD EDGE INSTALLATION GUIDE FOR COMPLETE FASTENING AND INSTALLATION INFORMATION FOR ES-1 RATED SNAP-ON COPING

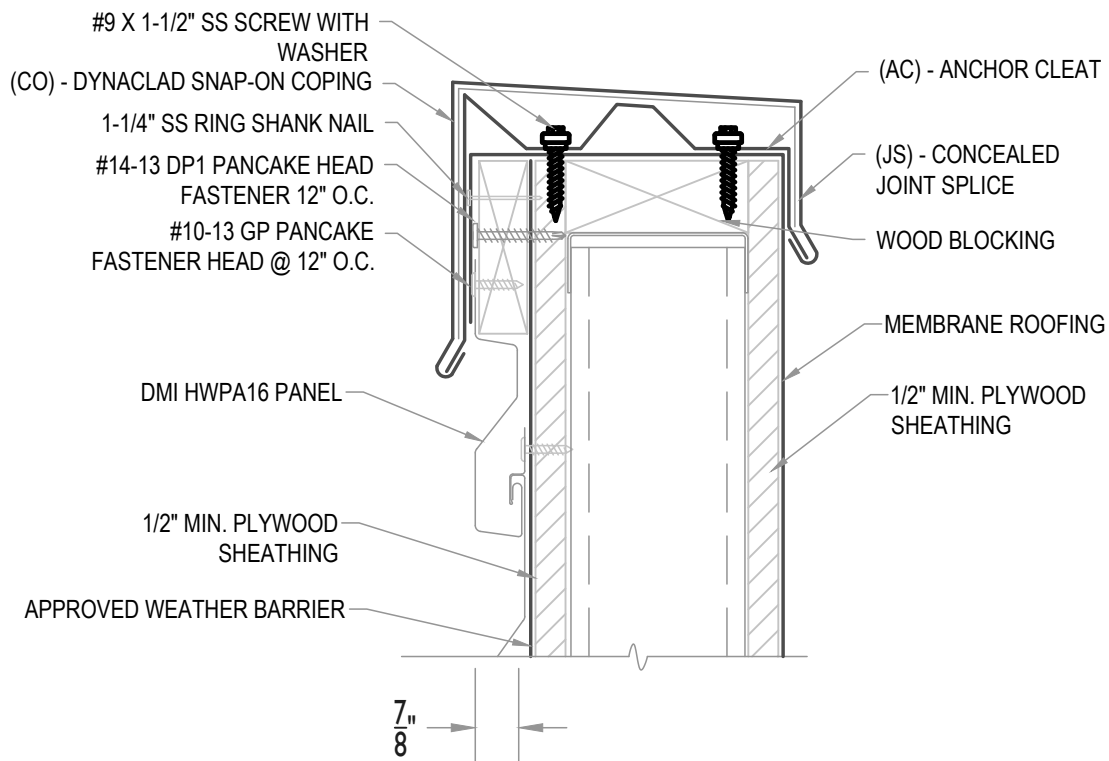

COPING WITH WOOD SUBSTRATE

• **PROVEN** • **DEPENDABLE** • **SUSTAINABLE** •

METAL ENVELOPE SYSTEMS SINCE 1988

WWW.DMIMETALS.COM

Detail:

HWP16-H-04-00

Issue/Rev Date:

04/19

Scale:

3"=1'-0"