

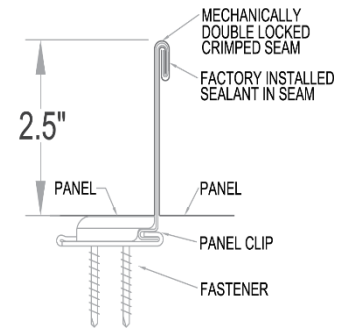

DOUBLE-LOCK DL25 STEEL

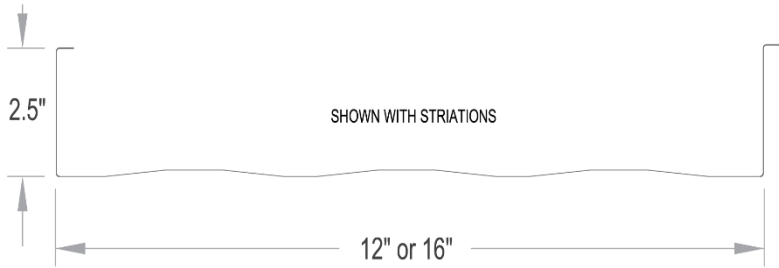

180 Deflection

SECTION PROPERTIES							ALLOWABLE UNIFORM LOADS, psf (single span)						
Ga.	Width in.	Yield ksi	Weight psf	Top in Compression			Inward Load						
				I_{xx} in ⁴ /ft.	I_{xx} (eff) in ⁴ /ft.	S_{xx} in ³ /ft	2.5'	3.0'	3.5'	4.0'	4.5'	5.0'	5.5'
24	12	50	1.55	0.3090	0.2621	0.1101	352.3	244.7	179.8	137.6	108.7	88.1	72.8
22	12	50	1.85	0.3837	0.3262	0.1422	455.0	316.0	232.2	177.8	140.4	113.8	94.0
24	16	50	1.87	0.2470	0.2080	0.0830	265.6	184.4	135.5	103.8	82.0	66.4	54.9
22	16	50	2.24	0.3070	0.2590	0.1070	342.4	237.8	174.7	133.8	105.7	85.6	70.7

SECTION PROPERTIES							ALLOWABLE UNIFORM LOADS, psf (two equal spans)						
Ga.	Width in.	Yield ksi	Weight psf	Top in Compression			Inward Load						
				I_{xx} in ⁴ /ft.	I_{xx} (eff) in ⁴ /ft.	S_{xx} in ³ /ft	2.5'	3.0'	3.5'	4.0'	4.5'	5.0'	5.5'
24	12	50	1.55	0.3090	0.2621	0.1101	352.3	244.7	179.8	137.6	108.7	88.1	72.8
22	12	50	1.85	0.3837	0.3262	0.1422	455.0	316.0	232.2	177.8	140.4	113.8	94.0
24	16	50	1.87	0.2470	0.2080	0.0830	265.6	184.4	135.5	103.8	82.0	66.4	54.9
22	16	50	2.24	0.3070	0.2590	0.1070	342.4	237.8	174.7	133.8	105.7	85.6	70.7

SECTION PROPERTIES							ALLOWABLE UNIFORM LOADS, psf (three equal spans)						
Ga.	Width in.	Yield ksi	Weight psf	Top in Compression			Inward Load						
				I_{xx} in ⁴ /ft.	I_{xx} (eff) in ⁴ /ft.	S_{xx} in ³ /ft	2.5'	3.0'	3.5'	4.0'	4.5'	5.0'	5.5'
24	12	50	1.55	0.3090	0.2621	0.1101	440.4	305.8	224.7	172.0	135.9	110.1	91.0
22	12	50	1.85	0.3837	0.3262	0.1422	568.8	395.0	290.2	222.2	175.6	142.2	117.5
24	16	50	1.87	0.2470	0.2080	0.0830	332.0	230.6	169.4	129.7	102.5	83.0	68.6
22	16	50	2.24	0.3070	0.2590	0.1070	428.0	297.2	218.4	167.2	132.1	107.0	88.4



DOUBLE-LOCK DL25 STEEL

240 Deflection

SECTION PROPERTIES							ALLOWABLE UNIFORM LOADS, psf (single span)						
Ga.	Width in.	Yield ksi	Weight psf	Top in Compression			Inward Load						
				I_{xx} in ⁴ /ft.	I_{xx} (eff) in ⁴ /ft.	S_{xx} in ³ /ft	2.5'	3.0'	3.5'	4.0'	4.5'	5.0'	5.5'
24	12	50	1.55	0.3090	0.2621	0.1101	352.3	244.7	179.8	137.6	108.7	88.1	72.8
22	12	50	1.85	0.3837	0.3262	0.1422	455.0	316.0	232.2	177.8	140.4	113.8	94.0
24	16	50	1.87	0.2470	0.2080	0.0830	265.6	184.4	135.5	103.8	82.0	66.4	54.9
22	16	50	2.24	0.3070	0.2590	0.1070	342.4	237.8	174.7	133.8	105.7	85.6	70.7

SECTION PROPERTIES							ALLOWABLE UNIFORM LOADS, psf (two equal spans)						
Ga.	Width in.	Yield ksi	Weight psf	Top in Compression			Inward Load						
				I_{xx} in ⁴ /ft.	I_{xx} (eff) in ⁴ /ft.	S_{xx} in ³ /ft	2.5'	3.0'	3.5'	4.0'	4.5'	5.0'	5.5'
24	12	50	1.55	0.3090	0.2621	0.1101	352.3	244.7	179.8	137.6	108.7	88.1	72.8
22	12	50	1.85	0.3837	0.3262	0.1422	455.0	316.0	232.2	177.8	140.4	113.8	94.0
24	16	50	1.87	0.2470	0.2080	0.0830	265.6	184.4	135.5	103.8	82.0	66.4	54.9
22	16	50	2.24	0.3070	0.2590	0.1070	342.4	237.8	174.7	133.8	105.7	85.6	70.7

SECTION PROPERTIES							ALLOWABLE UNIFORM LOADS, psf (three equal spans)						
Ga.	Width in.	Yield ksi	Weight psf	Top in Compression			Inward Load						
				I_{xx} in ⁴ /ft.	I_{xx} (eff) in ⁴ /ft.	S_{xx} in ³ /ft	2.5'	3.0'	3.5'	4.0'	4.5'	5.0'	5.5'
24	12	50	1.55	0.3090	0.2621	0.1101	440.4	305.8	224.7	172.0	135.9	110.1	91.0
22	12	50	1.85	0.3837	0.3262	0.1422	568.8	395.0	290.2	222.2	175.6	142.2	117.5
24	16	50	1.87	0.2470	0.2080	0.0830	332.0	230.6	169.4	129.7	102.5	83.0	68.6
22	16	50	2.24	0.3070	0.2590	0.1070	428.0	297.2	218.4	167.2	132.1	107.0	88.4

NOTES:

- Theoretical section properties have been calculated per AISI 2012 North American Specification for the Design of Cold-Formed Steel Structural Member.
- I_{xx} and S_{xx} are effective section properties for deflection and bending.
- Allowable load is calculated in accordance with AISI 2012 specifications considering bending, shear, combined bending and shear and deflection. Allowable load considers a 3 or more equal span condition.
- Allowable load does not address web crippling, fasteners, connection strength or support material.
- Panel weight is not considered.
- Load/Span values are based on theoretical computations and not load testing.
- Deflection consideration is limited by a maximum deflection ratio of $L/180$ or $L/240$ of span.
- Allowable loads do not include a $1/3$ stress increase for wind.