

- Step 1: Fold small lip 180°
- Step 2: Fold outer lip (approx.) 180°
- Step 3: Notch zee closure.
- Step 4: Apply two rows of butyl tape to underside of zee.

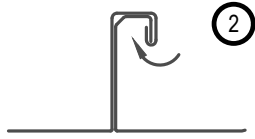

- Step 5: Install zee closure.
- Step 6: Seal corners of zee and panel legs and entire perimeter of panel backer plate juncture.
- Step 7: Attach top of zee to panel rib.
- Step 8: Fasten zee through panel to backer plate

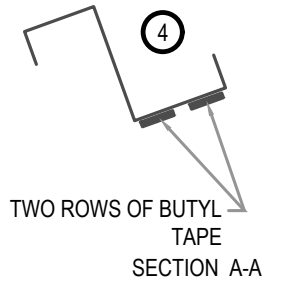
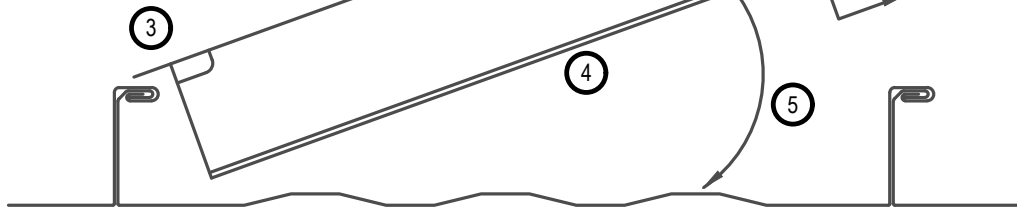
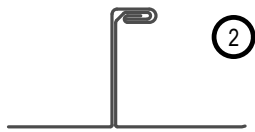

INJECT APPROVED SEALANT IN CORNERS AND ENTIRE PANEL BACKER PLATE JUNCTURE

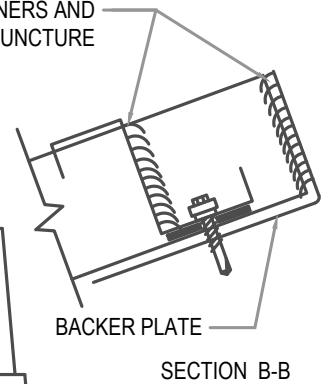
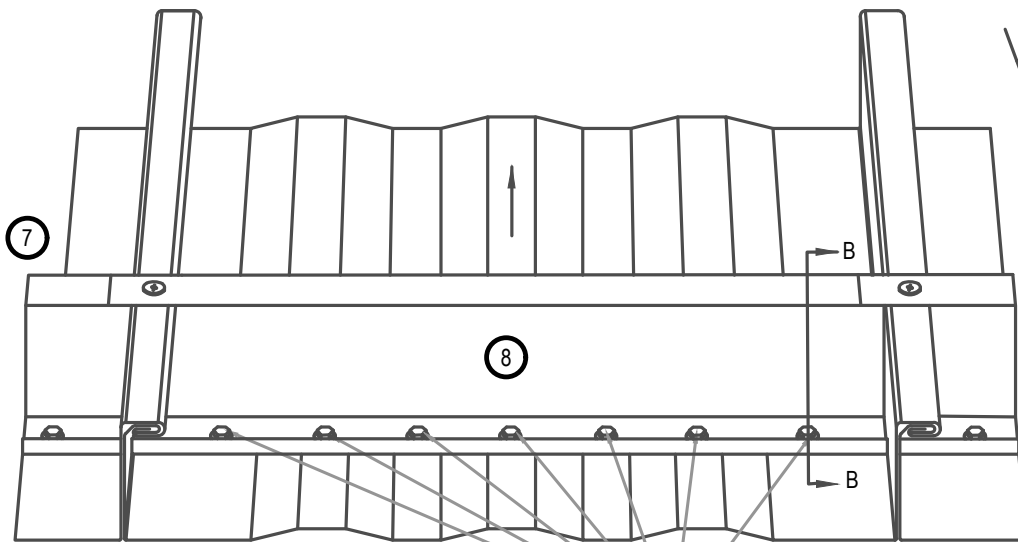

NOTE: BACKER PLATE NOT SHOWN FOR CLARITY

FASTENERS PER SHOP DRAWINGS



HYDROSTATIC Z INSTALLATION GUIDE

• **PROVEN** • **DEPENDABLE** • **SUSTAINABLE** •
METAL ENVELOPE SYSTEMS SINCE 1988

WWW.DMIMETALS.COM

Detail:
DL20 11-00-WH

Issue/Rev Date:

01/17

Scale:

3"=1'-0"