

**FLASHING LAP NOTE**

LAP EXPANSION JOINT AND J CLOSURE 2" MINIMUM WITH 2 ROWS OF BUTYL SEALANT.

**FASTENER NOTE**

ALL EXTERIOR FASTENERS ARE TO BE EITHER STAINLESS OR PLATED CARBON STEEL.

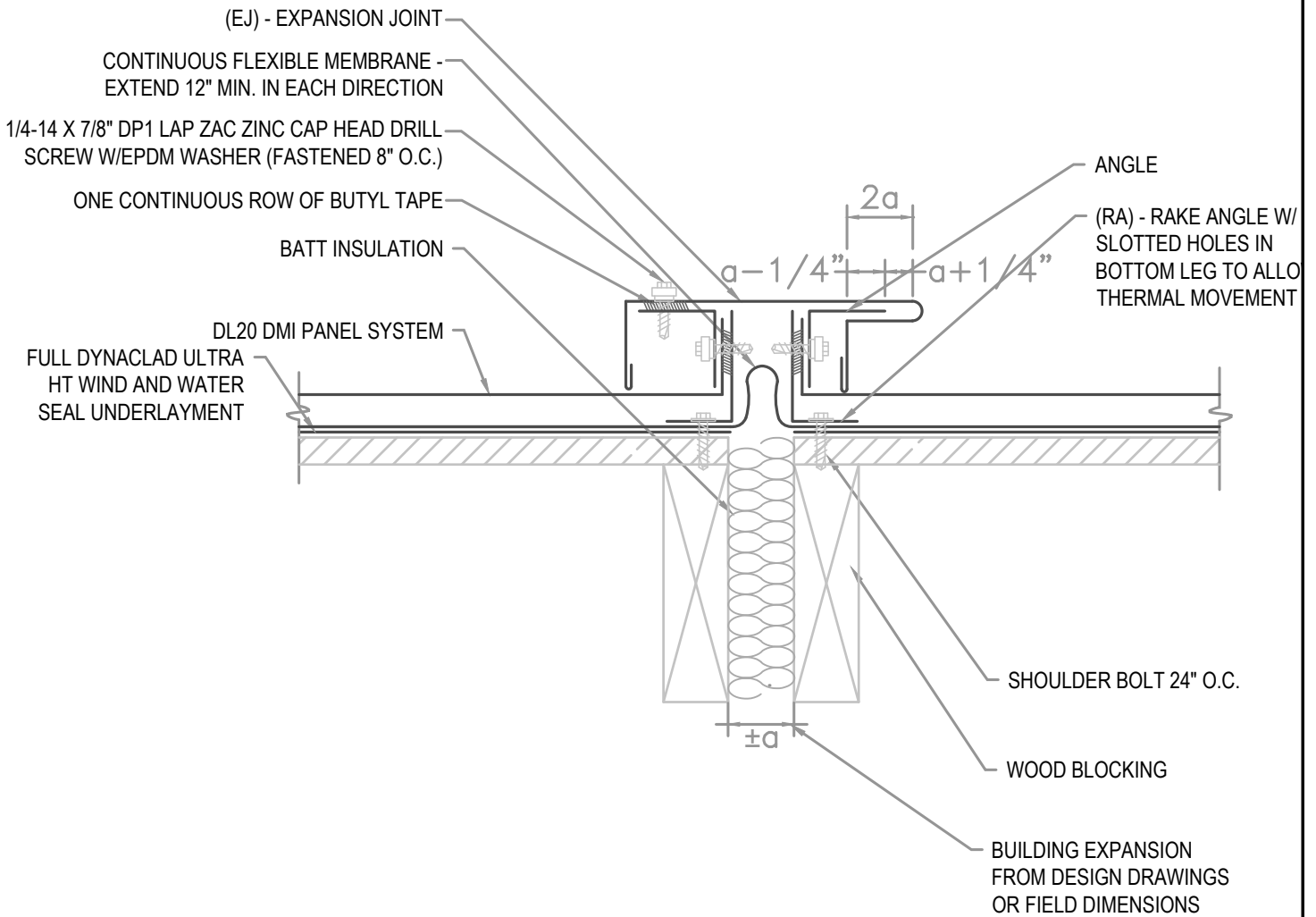

**HYDROSTATIC EXPANSION JOINT**

• **PROVEN** • **DEPENDABLE** • **SUSTAINABLE** •  
**METAL ENVELOPE SYSTEMS SINCE 1988**

WWW.DMIMETALS.COM

Detail:

**DL20 08-00-WH**

Issue/Rev Date:

**01/17**

Scale:

**3"=1'-0"**