

SECTION "A"

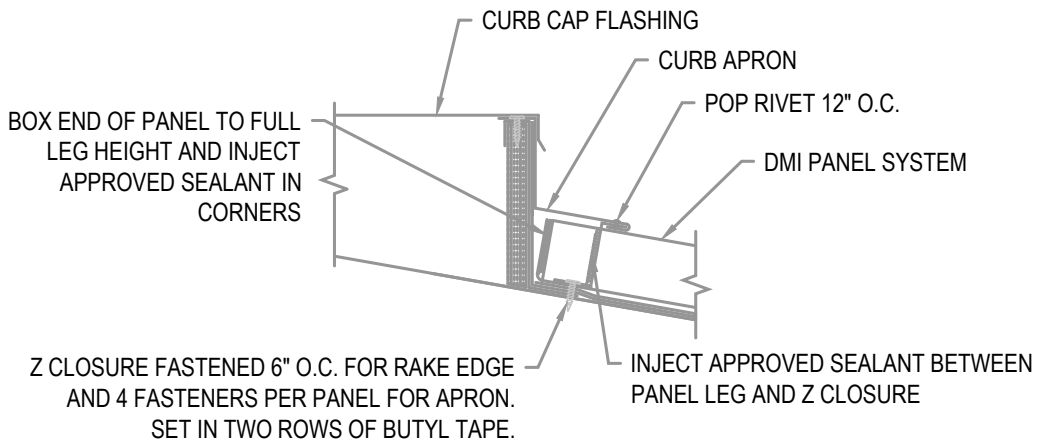

SECTION "B"



ARCHITECTURAL CURB

• **PROVEN** • **DEPENDABLE** • **SUSTAINABLE** •
METAL ENVELOPE SYSTEMS SINCE 1988

WWW.DMIMETALS.COM

Detail:

DL15 12-00-IA

Issue/Rev Date:

01/17

Scale:

3"=1'-0"