

**FLASHING LAP NOTE**

LAP RAKE EDGE AND FASCIA 2" MINIMUM WITH 2 ROWS OF BUTYL SEALANT.

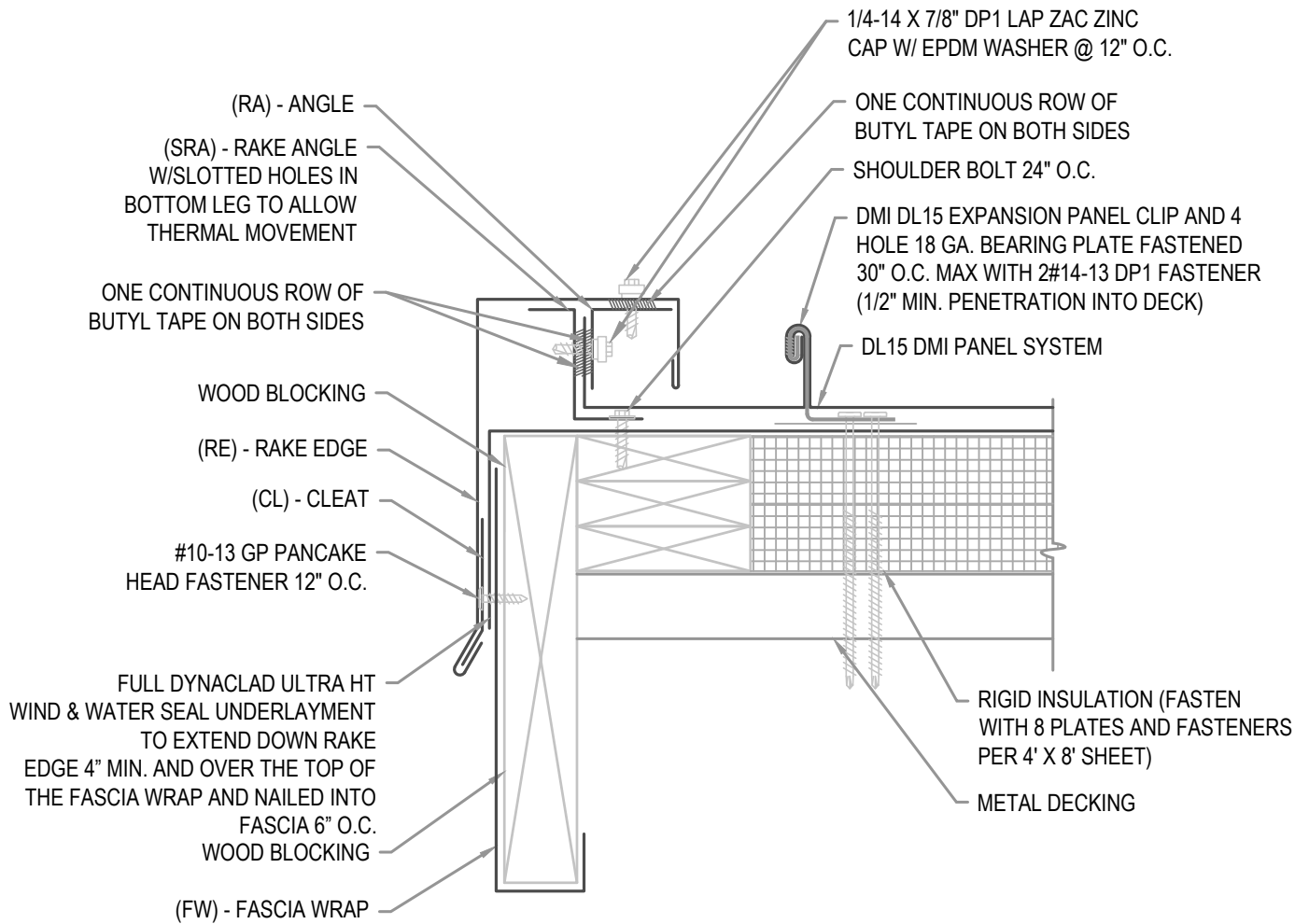

**ARCHITECTURAL RAKE EDGE**

• **PROVEN** • **DEPENDABLE** • **SUSTAINABLE** •  
**METAL ENVELOPE SYSTEMS SINCE 1988**

[WWW.DMIMETALS.COM](http://WWW.DMIMETALS.COM)

Detail:

**DL15 04-02-IA**

Issue/Rev Date:

**01/17**

Scale:

**3"=1'-0"**